

Izolované a neizolované lisovacie dutinky

Izolované lisovacie dutinky

Materiál: elektrovodivá meď. Izolácia: Polyamid 6,6 (PA 6,6). Teplotný rozsah: -50 °C ... +105 °C.

Tvar dutiniek	Obj. číslo	Alternatívna farba (NFC)	Tvar dutiniek	Obj. číslo	Štandardná farba (DIN-VDE)	Prierez vodiča (mm ²)	d ₁ (mm)	d ₂ (mm)	L (mm)	I (mm)	S ₁ (mm)	S ₂ (mm)
Oranžovo podfarbené typy sú najbežnejšie používané lisovacie dutinky.	E034	fialová		E134	svetlomodrá	0.25	0.8	1.5	10.4	6	0.15	0.25
				E135	svetlomodrá	0.25	0.8	1.5	12.8	8	0.15	0.25
	E05	modrá		E136	tyrkysová	0.34	0.5	1.8	10.4	6	0.15	0.3
				E137	tyrkysová	0.34	0.8	2	12.8	8	0.15	0.3
				E010	oranžová	0.5	1	2.6	12	6	0.15	0.25
	E09	červená		E020	oranžová	0.5	1	2.6	14	8	0.15	0.25
				E030	oranžová	0.5	1	2.6	16	10	0.15	0.25
				E040	biela	0.75	1.2	2.8	12.4	6	0.15	0.25
	E13	čierna		E050	biela	0.75	1.2	2.8	14.6	8	0.15	0.25
				E060	biela	0.75	1.2	2.8	16.4	10	0.15	0.25
			E070	biela	0.75	1.2	2.8	18.4	12	0.15	0.25	
			E080	žltá	1	1.4	3	12.4	6	0.2	0.3	
E16	sivá		E090	žltá	1	1.4	3	14.6	8	0.2	0.3	
			E100	žltá	1	1.4	3	16.4	10	0.2	0.3	
			E110	žltá	1	1.4	3	18.4	12	0.2	0.3	
E19	oranžová		E113	červená	1.5	1.7	3.5	14.6	8	0.15	0.25	
			E114	červená	1.5	1.7	3.5	16.4	10	0.15	0.25	
			E115	červená	1.5	1.7	3.5	18.4	12	0.15	0.25	
E22	zelená		E116	modrá	2.5	2.3	4	15.2	8	0.15	0.25	
			E117	modrá	2.5	2.3	4	19.2	12	0.15	0.25	
			E118	modrá	2.5	2.3	4	25.2	18	0.15	0.25	
			E119	sivá	4	2.8	4.4	16.5	9	0.2	0.3	
E24	hnedá		E120	sivá	4	2.8	4.4	19.5	12	0.2	0.3	
			E121	sivá	4	2.8	4.4	25.5	18	0.2	0.3	
			E122	čierna	6	3.5	6.3	20	12	0.2	0.3	
E26	sl. kost'		E123	čierna	6	3.5	6.3	26	18	0.2	0.3	
			E124	sl. kost'	10	4.5	7.6	21.5	12	0.2	0.4	
E28	čierna		E125	sl. kost'	10	4.5	7.6	27.5	18	0.2	0.4	
			E126	zelená	16	5.8	8.8	22.2	12	0.2	0.4	
E29	čierna		E127	zelená	16	5.8	8.8	28.2	18	0.2	0.4	
			E128	hnedá	25	7.5	11.2	29	16	0.2	0.4	
E30	červená		E129	hnedá	25	7.5	11.2	35	22	0.2	0.4	
			E130	sl. kost'	35	8.3	12.7	30	16	0.2	0.4	
E32	modrá		E131	sl. kost'	35	8.3	12.7	39	25	0.2	0.4	
			E132	olivová	50	10.3	15.3	36	20	0.3	0.6	
			E133	olivová	50	10.3	15.3	41	25	0.3	0.6	
			E140	žltá	70	13	16.7	37.5	21	0.5	0.75	
E32	modrá		E142	červená	95	14.5	18	43.6	25	0.6	1	
			E144	modrá	120	16.6	20.4	48	27	0.6	1	
E32	modrá		E146	žltá	150	20	23.5	58	32	0.6	1	

Technické parametre doporučeného lisovacieho náradia vid' v kap. B.

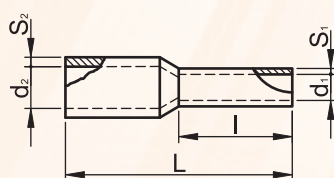

PRÍSLUŠNÉ NORMY
STN EN 61238-1
STN 371340, 345615

EVPÚ CERTIFICATE NO.
02336/101/1/2001



Izolované a neizolované lisovacie dutinky

A

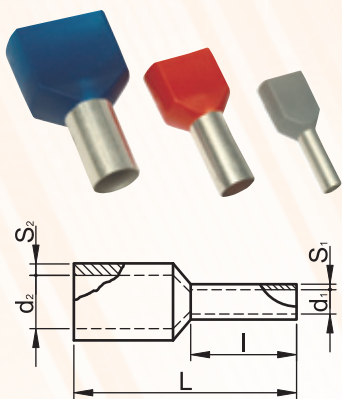

Dvojité izolované lisovacie dutinky

Materiál: elektrovodivá meď. Izolácia: Polyamid 6,6 (PA 6,6). Teplotný rozsah: -50 °C ... +105 °C.

Tvar dutiniek	Obj. číslo	Farba	Prierez vodiča (mm ²)	d ₁ (mm)	d ₂ (mm)	L (mm)	I (mm)	S ₁ (mm)	S ₂ (mm)
	E20I	biela	2×0.5	1.5	4.7	15	8	0.2	0.5
	E50I	sivá	2×0.75	1.8	5	16	8	0.2	0.4
	E50IH	sivá	2×0.75	1.8	5	17.5	10	0.2	0.5
	E90I	červená	2×1.0	2.3	5.4	15	8	0.15	0.3
	E90IH	červená	2×1.0	2.3	5.4	18	10	0.2	0.5
	E13IR	čierna	2×1.5	2.3	6.5	16	8	0.2	0.4
	E13I	čierna	2×1.5	2.3	6.5	20	12	0.15	0.3
	E16IR	modrá	2×2.5	2.8	7.8	20	10	0.2	0.5
	E16I	modrá	2×2.5	2.8	7.8	22.5	13	0.2	0.5
	E19I	sivá	2×4.0	3.8	9	23.5	12	0.2	0.5
	E22I	žltá	2×6.0	4.9	10.2	25.5	14	0.2	0.4
	E24I	červená	2×10.0	6.5	13	26.5	14	0.2	0.5
	E26I	modrá	2×16.0	8.3	18.7	32	14.5	0.3	0.5

PRÍSLUŠNÉ NORMY

STN EN 61238-1
STN 371340, 345615
DIN 46228

Doporučené lisovacie náradie pre dvojité izolované dutinky vid' v nižšie uvedenej tabuľke, ich technické parametre vid' v kap. B.

Neizolované lisovacie dutinky

Materiál: galvanicky pocínovaná elektrovodivá meď. Oranžovo podfarbené typy sú najbežnejšie používané lisovacie dutinky.

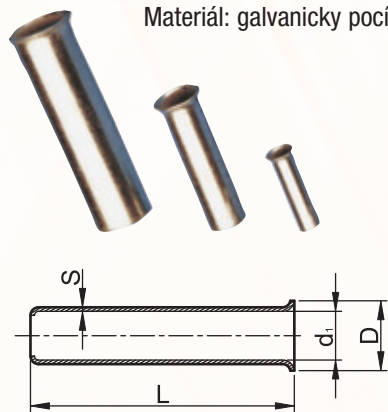

Obj. číslo	Prierez vodiča (mm ²)	D (mm)	d ₁ (mm)	S (mm)	L (mm)
E00NR6	0.25	1.6	0.7	0.2	5
E01NR6	0.5	1.8	1	0.2	6
E01NR	0.5	2.2	1.2	0.2	8
E02NR	0.75	2	1.1	0.2	8
E03NR	1.0	2.2	1.3	0.2	8
E04NR	1.5	2.5	1.7	0.2	8
E05NR	2.5	3.3	2.3	0.2	8
E06NR	4.0	3.9	2.8	0.2	10
E07NR	6.0	4.7	3.5	0.2	12
E08NR	10.0	5.9	4.6	0.2	12
E01N	0.5	2	1	0.2	10
E02N	0.75	2.2	1.2	0.2	10
E03N	1.0	2.3	1.4	0.2	10
E04N	1.5	2.6	1.7	0.2	10
E05N	2.5	3.3	2.2	0.2	10
E06N	4.0	4	2.8	0.2	12
E07N	6.0	4.7	3.5	0.2	15
E08N	10.0	5.6	4.5	0.2	15
E09N	16.0	7.4	5.9	0.2	15
E10N	25.0	9.1	7.2	0.2	15
E11N	35.0	10.2	8.1	0.25	18
E12N	50.0	13	10.3	0.3	20
E13N	70.0	15.3	13.5	0.4	22
E14N	95.0	16.8	14.6	0.4	32

Doporučené náradie k izolovaným a neizolovaným dutinkám

Obj. číslo	Lisovací rozsah (mm ²)
9102-LT	0.25-2.5
9004-LT	0.5-16
9039	6-16
9039A	0.5-6
9039B	10-35
9039AR	0.5-6
9039BR	10-35
9039A-SPEC	0.25-6
9039B-SPEC	6-16

Technické parametre doporučeného lisovacieho náradia vid' v kap. B.

PRÍSLUŠNÉ NORMY

STN EN 61238-1

PRÍSLUŠNÉ NORMY

DIN 46228/1

EVPU CERTIFICATE NO.

02336/101/1/2001